

Diesel Powered Generating Sets

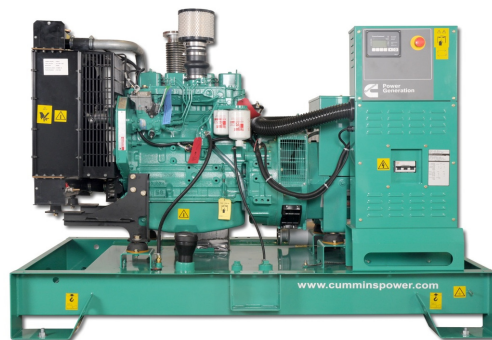

C70D5

Our energy working for you.™



Standard Genset Features

Cummins water cooled Diesel engine.
Oil and fuel filter fitted, water separator.
Lube-oil drain valve fitted.
Electric starter and Charge alternator 12 VDC.
Mechanical governor,
Normal duty air filter.
Single bearing alternator.
Set mounted starting battery.
Engine, Alternator, Chassis and Control Command House color: Munsell Jade Green.
Radiator and Guarding in color: Black.
Packing under shrunk plastic film.
Operation and Maintenance manual.
Standard set of labels.
Fuel tank in skid - day tank.

Optional

PMG (Permanent Magnet Generating)

Offers enhanced motor starting, good performance with non-linear loads and faultclearing short circuit capability.

Warranty Standard

Warranty 2 years (Standby) or 1 year (Prime Power)

Exhaust

Exhaust silencer - Industrial 09 dB(A)
Exhaust silencer - Residential 29 dB(A)

Warranty

Warranty 5 years extended - (Standby)
Warranty 2 years extended or 6000 hours - (Prime)

Fuel consumption

Ratings	Standby				Prime			
	70 kVA		56 kW		63 kVA		50 kW	
Load	Full	3/4	1/2	1/4	Full	3/4	1/2	1/4
Consumption (L/hr)	14	11	8	5	13	10	8	5

Observation:

The engine above was tested according to the ISO-3046 respecting the following conditions:

Barometric Pressure = 100 kPa (29.83 in Hg)

Altitude above sea level = 110 m (316 ft)

Ambient temperature = 25° c (77° F)

Relative humidity = 30%

Generator Set Performance

Voltage Regulation

Maintains voltage output within $\pm 1,0\%$ in the following conditions:

1. At any power factor between 0.8 and 1.0
2. At any load level from no load to full load.
3. At speed droop variations up to 4,5%.

Frequency Regulation

Isochronous under any load, from no load to 100% full load when electronic governor is fitted.

Random Frequency Variation

Will not exceed $\pm 0,25\%$ of rated frequency value for constant loads, no load to full load.

Compliance Standards

To BS4999/5000 pt 99,
VDE 0530, UTE5100,
NEMA MG1-22, CEMA,
IEC 34, CSA A22.2,
AS1359, BSS 5514,
ISO 3046 and ISO 8528

Generator Set Options

Options

Coolant heater
Battery Charger
Automatic Transfer Switches - GTEC
Silencer Enclosures
Electronic governor
External Tank
Heavy Duty air filter

Alternator Specification

Type

Brushless single bearing, revolving field, four pole.
Protection from water (dripping).
Class H Insulation, IP23 Protection.
Vacuum impregnation.
IC 01 cooling system.
Fully interconnected damper winding.
AC exciter and rotating rectifier unit.
Epoxy coated stator winding.
Rotor and exciter impregnated with polyester resin appropriate to the tropical climate, resistant to oil and acids.
Rotor balanced dinamically BS 5625 2,5 degrees.
Rotor wound in layers and with mechanics coins.
Permanent lubricant ball bearing

Exciter

Triple dipped in varnish resistant to oil and acid and coated with anti-tracking varnish.

Winding

Low reactance 2/3 pitch windings; low waveform distortion with non-linear loads, fault clearing short-circuit capability.
Engine/alternator direct coupling for perfect alignment.

Voltage Connections - 50 Hz

480/277 V 380/220 V 220/127 V
440/254 V 240/139 V 208/120 V
416/240 V

Technical Data

Model	C70D5	Alternator voltage regulation	± 1,0%
Standby Rating	70 kVA / 56 kW	Alternator insulation class	H
Prime Rating	63 kVA / 50 kW	IP Protection	IP 23
Engine Make	Cummins	Fuel consumption (Standby)	14 l/h
Engine Model	4BT 3.9-G4	Fuel consumption (Prime)	13 l/h
Cylinders	4 cylinders	Lubrication system oil capacity	10,9 l
Engine Build	In line	Coolant capacity (only engine)	7,2 liters
Standard Governor/Class	Mechanical	Coolant capacity (engine and radiator)	17,3 liters
Aspiration and cooling	Turbocharged	Exhaust temperature (Prime)	523°C
Bore and stroke	102 mm x 120 mm	Exhaust gas flow (Prime)	170 l/s
Compression Ratio	16,5 : 1	Exhaust gas back pressure max	76 mm Hg
Cubic capacity	3,92 liters	Air flow radiator	2,0 m³/s
Starting/Min °C	Unaided / -12°C	Intake air flow	66 l/s
Battery capacity	(1x) 75 A/h	Minimum air opening to room	0,7 m²
Gross Engine output – Standby	64 kWm	Minimum discharge opening	0,5 m²
Gross Engine output – Prime	58 kWm	Radiated heat to ambient	17,1 kWm
Speed	1500 rpm	Tank incorporated in the base capacity	200 liters

STANDBY POWER RATING (ESP)

The Standby Power Rating is applicable for supplying emergency power for the duration of a utility power interruption. No overload, utility parallel or negotiated outage operation capability is available at this rating. In installations served by unreliable utility sources (where outages last longer or occur more frequently), where operation is likely to exceed 200 hours per year, the prime power rating should be applied.

PRIME POWER (PRP)

Prime power is available for an unlimited number of annual operating hours in variable load applications, in accordance with ISO8528-1. A 10% overload capability is available for a period of 1 hour within a 12-hour period of operation.

All ratings are based on the following reference conditions:

- Ambient temperature: 27°C

- Altitude above sea level: 150 meters

- Relative humidity: 60%

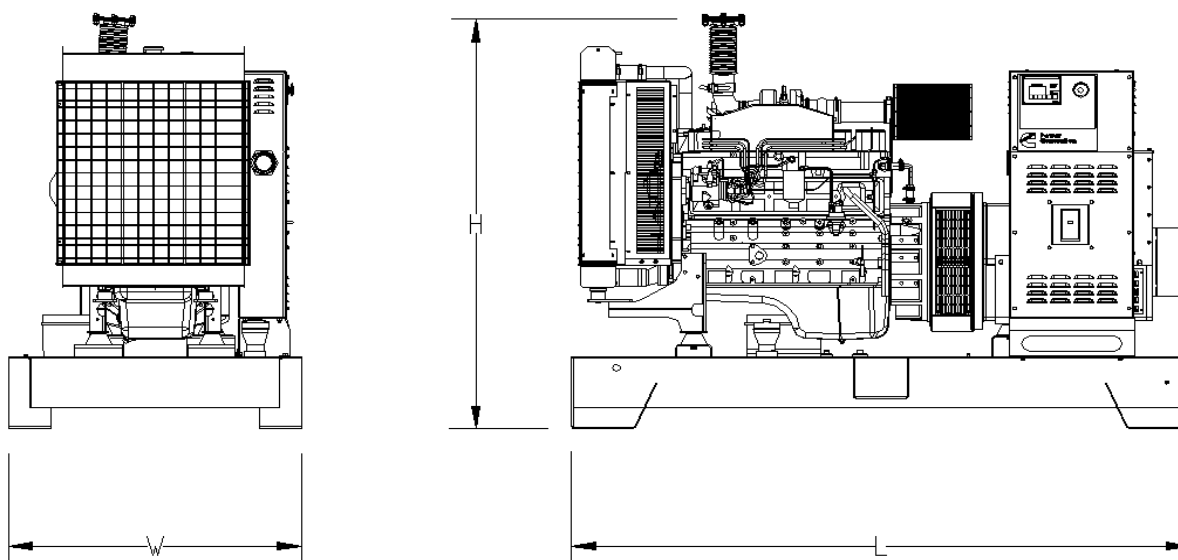

This outline drawing is for reference only. Do not use for installation design

Dimensions and Weights

Genset	Length (mm) L	Width (mm) W	Height (mm) H	Set weight dry (kg)	Set weight wet (kg)*
Open Set	1920	1050	1512	935	1153
Enclosed Set - F190	2730	1090	1865	1419	1619

*Set weight wet represent a set with oil, fuel and coolant liquid.



Cummins Brasil Ltda.
Rua Jati, 310 - Cumbica
Guarulhos - SP - Brasil
Zip Code: 07180-900
Phone: (55 11) 2186-4195
www.cumminspower.com.br

the
Power
of One

See your distributor for more information.