

THE KTA19 G-DRIVE

ALWAYS ON.
RELIABLE
POWER ACROSS
ALL CONDITIONS

A detailed view of a Cummins KTA19 G-Drive engine, showing its complex mechanical components, including the large cooling fan on the right, various pipes, and the engine block. The engine is set against a background of a glowing network of white lines and nodes, suggesting a high-tech or industrial environment. The overall color palette is dominated by reds, greys, and whites.

POWERED
BY
Cummins
G-DRIVE

EXCEPTIONAL PERFORMANCE IN THE TOUGHEST ENVIRONMENTS

INTRODUCING THE REINVENTED KTA19 G4 FROM CUMMINS with standard engine monitoring, diagnostics, protection and control technology. Cummins PT fuel system provides improved fuel efficiency and enhanced engine performance. Aftercooled for more efficient combustion and reduced internal stresses for a longer life, the KTA19 delivers best in class low derating thresholds for temperature and altitude.

18.9 litre, inline 6 cylinder, dual speed diesel engine rated at 550kVA/500kWe at 50Hz/60Hz. Capable of:

- ISO 8528-G2 performance with excellent load acceptance
- Fast start-up performance, capable of meeting NFPA110 standards
- Replaceable wet cylinder liners for lower overhaul cost
- Simple design for ease of service
- Smaller lube oil capacity

Part of the world renowned K series family – recognised across borders for strength and durability.

KTA19-G4, 1500rpm

Standby: 550kVA

Prime: 500kVA

KTA19-G4, 1800rpm

Standby: 500kWe

Prime: 455kWe

FLEETGUARD SPIN-ON FUEL FILTRATION SYSTEM

Blocks impurities down to 10 microns for better protection against fuel system contamination from dust, dirt or water.

STANFAST AND COOLPACS

Offering a complete solution validated to the highest engineering standards.

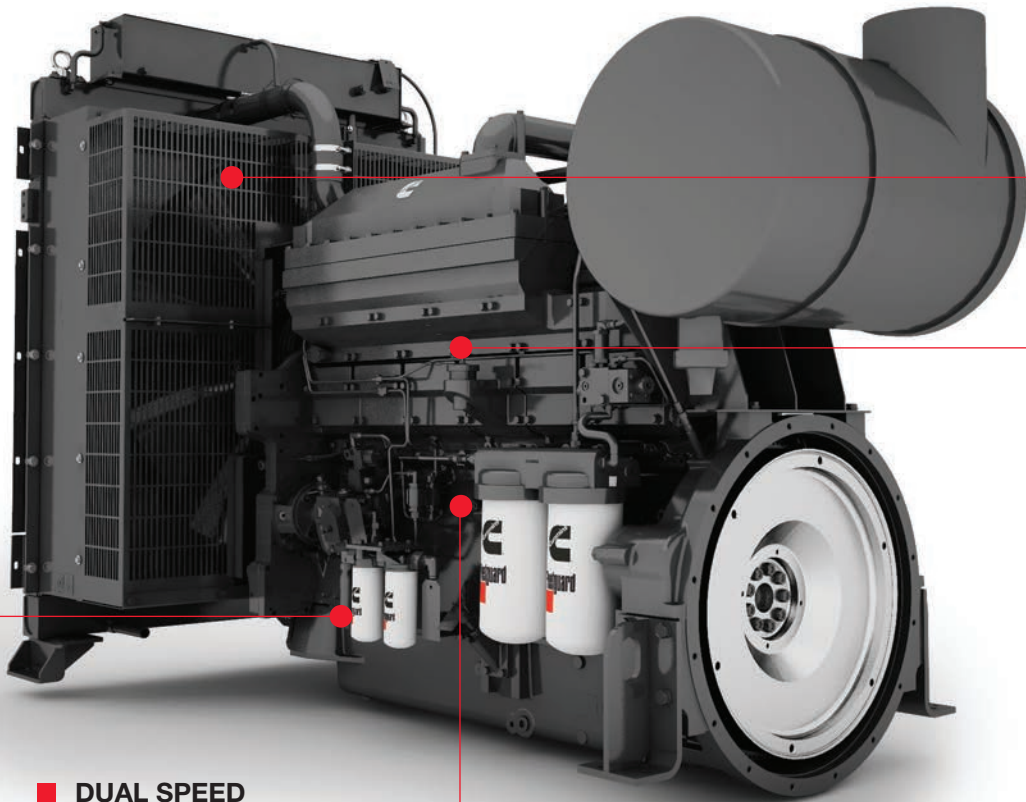

■ **DUAL SPEED
(1500RPM AND
1800RPM)**
Electronic fuel control
dual speed engine.

■ **CYLINDER LINER**
For lower maintenance costs.

■ **HIGH AMBIENT
COOLING SYSTEM**
50°C Limiting Ambient Temp
Capability – supplied kitted.

■ **CUMMINS PT FUEL SYSTEM**
Similar architecture as the
world-renowned KTA50
platform. Capable of operating
on low quality, high PPM fuel.

■ **NO DERATE UP TO
500M AT 50°C**
Best in class derating
thresholds for temperature
and altitude.

GLOBAL INTEGRATION AND AFTERMARKET SUPPORT

**8000
DISTRIBUTOR
AND DEALER
LOCATIONS.**

No matter where you are, your local Cummins distributor or dealer is your first line of support for everything from application assistance and on-site commissioning to troubleshooting, maintenance and aftermarket services.



ALWAYS ON™
cummins.com

Bulletin 5600489 2/20
©2020 Cummins Inc.